

RWY 25

AERODROME OBSTACLE CHART - ICAO

KRISTIANSUND/KVERNBERGET

NORWAY

DIMENSIONS AND ELEVATIONS IN METRES ABOVE MEAN SEA LEVEL

TYPE A - OPERATING LIMITATIONS

MAGNETIC VARIATION 1,4° E - 2015

DECLARED DISTANCES

RWY 07		RWY 25	
2080	TAKE-OFF RUN AVAILABLE	2070	
2380	TAKE-OFF DISTANCE AVAILABLE	2370	
2080	ACCELERATE STOP DISTANCE AVAILABLE	2070	
2000	LANDING DISTANCE AVAILABLE	2000	

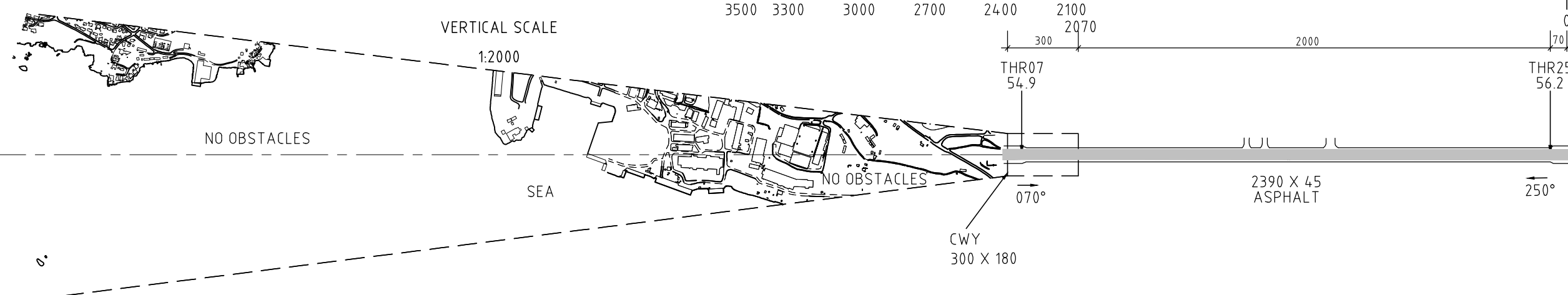
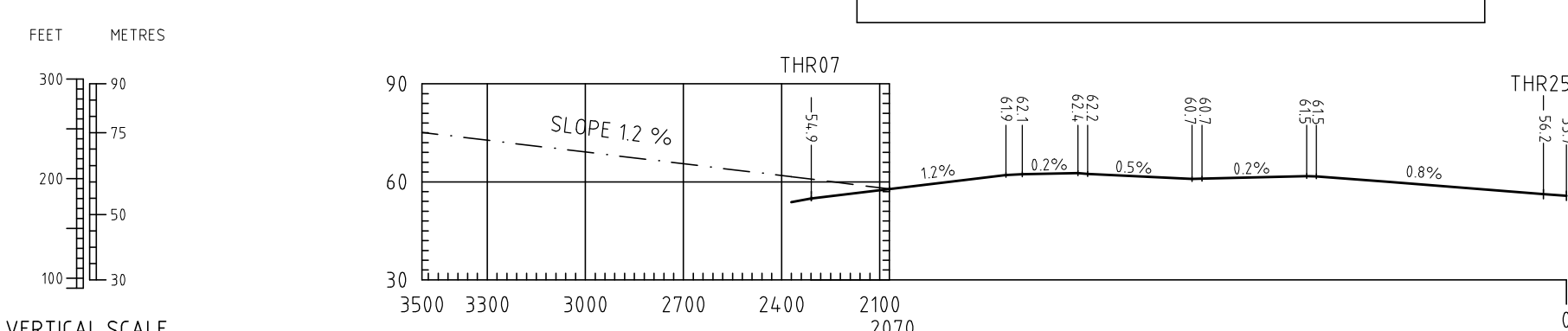
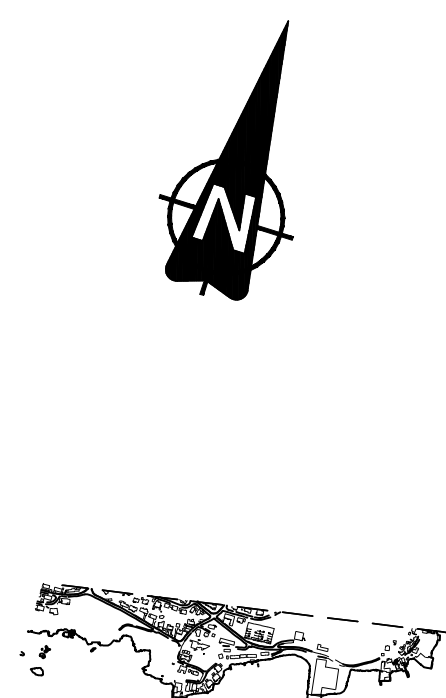

LEGEND	
IDENTIFICATION NUMBER	①
BUILDING OR LARGE STRUCTURE	■
TREE	*
POLE, TOWER, ANTENNA, ETC.	⊙
ROAD	— — — — —
COAST	— — — — —
LAKE, RIVER	— — — — —
TRANSMISSION LINE	— T — — — — —
RAILWAY	— — — — —
TERRAIN CONTOUR	— — — — —
TERRAIN PENETRATING OBSTACLE PLANE	— — — — —

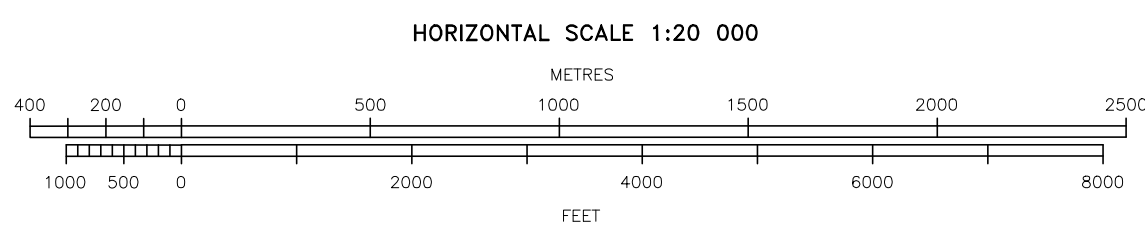

AMENDMENT RECORD		
No.	DATE	ENTERED BY

CHANGES: EDITORIALS: